

HYGRODYNAMICS

HUMIDITY/DEWPOINT TRANSMITTERS

6380WR & 6380DP SERIES

TABLE OF CONTENTS

1	GENERAL DESCRIPTION	2
2	SPECIFICATIONS	2
3	INSTALLATION	3
	PC BOARD TRANSMITTER SYSTEMS	3
	ENCLOSED MODELS	4
	WIRING	5
4	OPERATION	6
5	MAINTENANCE.....	6
6	PRODUCT WARRANTY	7

Newport Scientific, Inc
8246-E Sandy Court
Jessup, Maryland 20794-9632
www.newport-scientific.com

e-mail
Newport888@aol.com

Phone
301.498.6700

FAX
301.490.2313

1 General Description

The 6380 Series Transmitters provide linear output signals representing dewpoint or relative humidity and process air temperature. Both 4-20mA and 0-5V signals are available for moisture and temperature readings. The transmitter uses digital and high precision analog circuitry which requires no field calibration.

Moisture measurement is accomplished with the low cost Hygrosensor®. This sensor is interchangeable and can be easily replaced in the field.

2 Specifications

Operating Voltage

-115V models	95VAC - 130VAC
-230V models	210VAC - 250VAC
-24V models	18VDC - 26VDC

Operating Temperature Range

Electronics	32°F to 122°F
Sensor	32°F to 140°F

Measurement Range

6380DP Dewpoint	10°F to 70°F @ 80°F air temp. (50-100°F recommended air temp. range)
6380WR Humidity	5-95%RH @ 80°F air temp. 10-98%RH @ 32°F air temp. 1-90%RH @ 140°F air temp.
Both models air temp.	32°F to 140°F

Typical Accuracy

6380DP Dewpoint	±2°F
6380WR Humidity	±2% RH @ 80°F air temp. ±3% RH over temp.
Both models air temp.	±2°F

Output Signal Load

4-20mA	500Ω MAX
0-5VDC	1kΩ MIN

PC Board Dimensions

2.81" W X 3.66" L

Output Scaling

6380DP Dewpoint	-40°F to 70°F = 4-20mA or 0-5V
6380WR Humidity	0 to 100% RH = 4-20mA or 0-5V
Both models air temp.	32°F to 149°F = 4-20mA or 0-5V

3 Installation

PC Board Transmitter Systems

Sensor

There are two basic sensing arrangements for measuring process air. Parts for either arrangement are available from Newport Scientific.

Remote Sensor- The sensor is housed in a manifold. This arrangement allows best control of measurement conditions. A filter can be used ahead of the manifold to ensure clean sample air, and a bleed valve or vacuum pump after the manifold provides constant air flow around the sensor.

The sensor manifold has two 1/8" NPT ports for connecting sample air tubing. Flow rate through the manifold should be between 1 and 5 SCFH.

Pipe Mount Sensor- The sensor is installed directly in a pipe fitting in the process air stream. The sensor and its 1" NPT male fitting are rated at 150PSI operation. This installation is simplest, but care should be taken to protect the sensor from oil or other contaminants.

Remote Sensor Assembly:

1. Observe the pin pattern on the sensor and match to the 4 pin insert (one pin is off center). Use moderate finger pressure to press the sensor into the 4 pin insert. The sensor does not need to seat fully into the 4 pin insert.
2. Place gasket over sensor and slide down until it seats against the lip of the 4 pin insert.
3. Slide sensor and 4 pin insert into manifold. Screw the hex nut onto manifold and hand tighten.

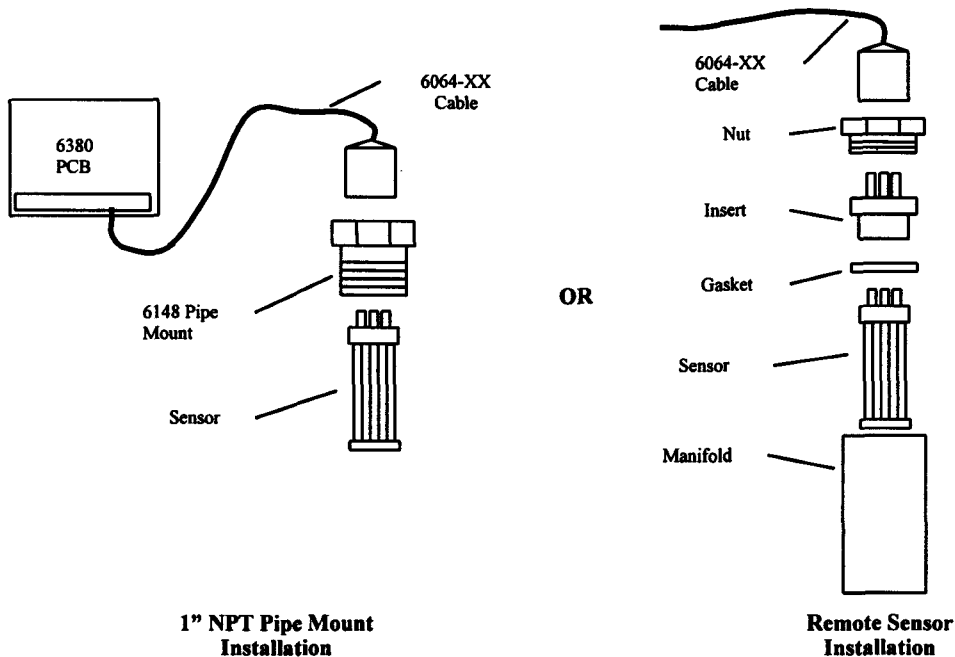

PC Board

Choose a dry location for the transmitter PC board. Mount transmitter PC board to panel with 1/4" standoffs.

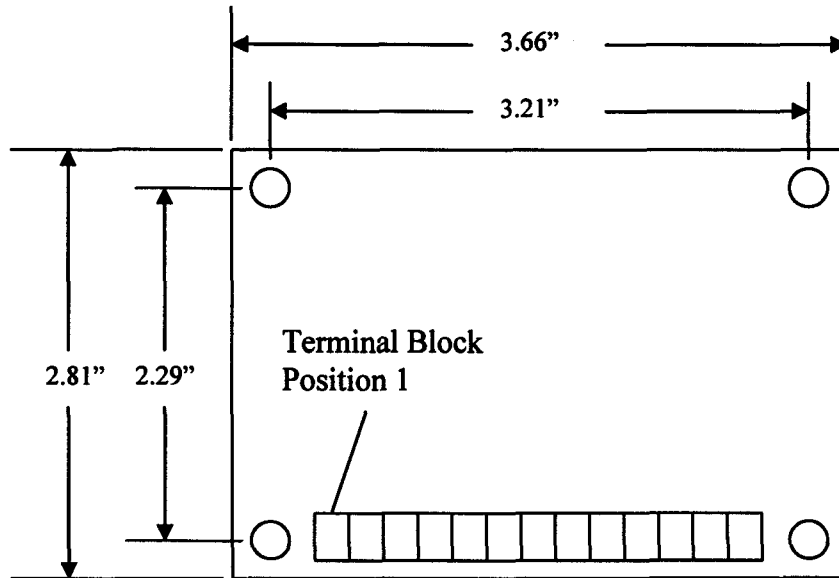

PC Board Mounting Dimensions

Enclosed Models

The 6380WR and 6380DP models are available in enclosed versions with sensors included. Remove the enclosure lid to access the enclosure mounting holes.

- 6380XXD Duct mount system with sensor attached to enclosure on back side.
- 6380XXR Remote mount system with sensor and flange connected to enclosure through 15' cable.
- 6380XXW Wall mount system with sensor attached to side of enclosure.

Wiring

For 6380 PC Boards with separate sensors, connect the sensor cable to the 4 pin insert as shown:

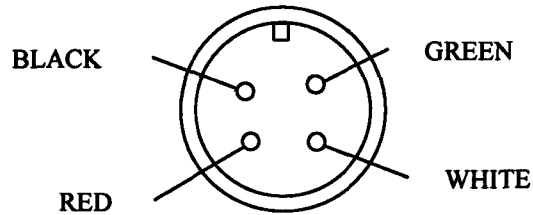

4 Pin Insert (Pin Side View)
Wire Color Code

Wire the terminal block as shown below:

Terminal 1	AC Line Hot (+ for DC operation)
Terminal 2	AC Line Neutral (- for DC operation)
Terminal 3	Power Ground
Terminal 4	0-5VDC Humidity/Dewpoint Output
Terminal 5	4-20mA Humidity/Dewpoint Output
Terminal 6	Sensor Input (a) Green
Terminal 7	Sensor Input (b) White
Terminal 8	Signal Ground
Terminal 9	Sensor Input (c) Red
Terminal 10	Sensor Input (d) Black
Terminal 11	0-5VDC Temperature Output
Terminal 12	4-20mA Temperature Output

4 Operation

Board Power

Line-powered boards will function with supply voltages in the range listed in the Specification Table. The on-board power supply includes over-voltage protection and surge suppression and can be used with confidence in noisy electrical environments.

24V models have on-board regulation and protection. Circuit performance is guaranteed within the voltage range listed in the specification table. Board operation is immune to 60Hz or 120Hz ripple as long as peak voltages remain in the operating range.

Ground

Power ground and Signal ground are connected together on the board. The lower left mounting hole is connected to this ground as well. If the board is mounted to a grounded chassis, this is normally the only ground connection required. The signal outputs are referenced to this ground.

Some sensor cables may have a ground wire. In this case, the sensor ground can be wired to terminal 8.

Signal Outputs

The system provides linear 4-20mA and 0-5VDC output signals. Both outputs can be used simultaneously without any interaction between the two.

Both outputs are short circuit protected.

Sensor Input

The sensor cable connects to sensor Terminals (a) through (d). If the sensor cable has a ground shield (used on some long cable applications), connect the shield to Terminal 3 or 8.

120V to 240V Supply Change

Warning: Remove power to board before change jumpers.

Remove jumpers J1 and J3, install jumper J2.

5 Maintenance

No calibration of the circuit is necessary. If false readings are evident, the sensor is probably bad. The sensor element should be replaced or the transmitter system should be sent to Newport Scientific for repair (please consult factory first).

6 Product Warranty

HYGRODYNAMICS LIMITED WARRANTY

NEWPORT SCIENTIFIC, INC. warrants that all equipment manufactured by NSI shall be free from defects in material and workmanship which might impair its usefulness. SELLER DOES NOT WARRANT THAT THE EQUIPMENT IS FIT FOR ANY PARTICULAR USE. THERE ARE NO WARRANTIES WHICH EXTEND BEYOND THE DESCRIPTION ON THE FACE HEREOF; the obligation under this warranty is limited to repairing or replacing, at Seller's factory, any defective parts which, when returned by the buyer, **TRANSPORTATION PREPAID**, examination discloses to have been factory defective. The time limit of this warranty is **ONE YEAR** from date of shipment of new equipment, **SIX MONTHS** from date of shipment of Hygrodynamics Wide-Range Sensors and **THREE MONTHS** from date of shipment of Hygrodynamics Narrow-Range Sensors and repaired equipment. **THIS WARRANTY IS EXPRESSLY IN LIEU OF OTHER WARRANTIES.** Seller shall not be held liable for any special, indirect, consequential damages arising out of this warranty or any breach thereof, of any defect in or failure or malfunction of the equipment and materials are further subject to tolerances and variations consistent with usages of trade. This warranty shall run in favor only of the purchaser from Seller and may not be passed on or represented on behalf of Seller to any subsequent purchaser.

WARRANTIES: OTHER PRODUCTS

NEWPORT SCIENTIFIC, INC. makes no express or implied warranty as to items, which are the products of other manufacturers. Seller shall use its best efforts to obtain from the manufacturer, in accordance with its customary practice, the repair or replacement of such products may prove defective in workmanship or material. The foregoing states the entire liability in respect to such products, except as an authorized executive of the corporation may otherwise agree in writing.

In the case of special equipment or modifications to standard equipment manufactured at the request of the buyer, under buyer-approved specifications, buyer will indemnify Seller against the risk damages due to patent infringement.

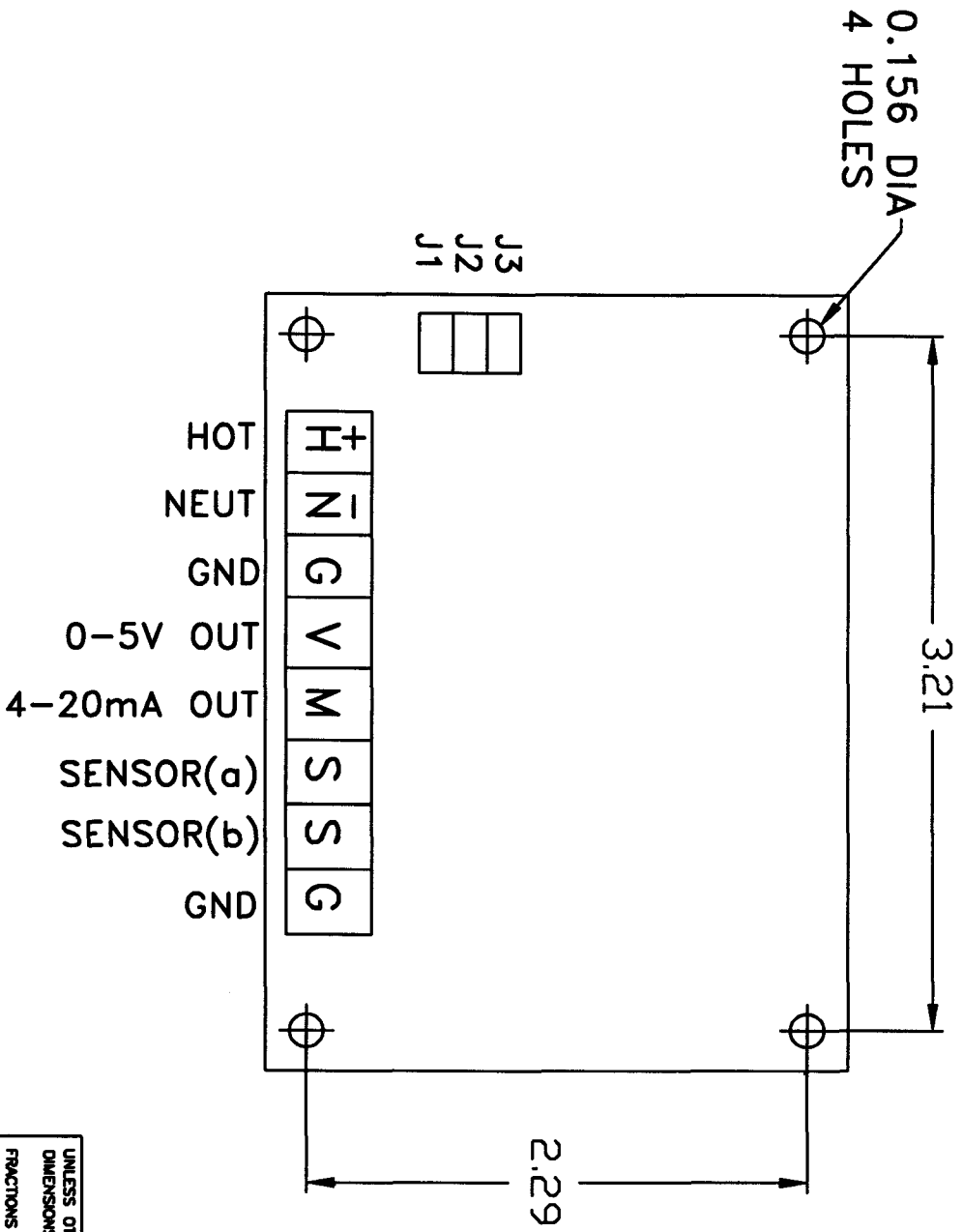

UNLESS OTHERWISE SPECIFIED
DIMENSIONS ARE IN INCHES
TOLERANCES:
FRACTIONS ±
DECIMALS ±
ANGLES ±
ROUND ALL DIMS AND SHARP EDGES
DO NOT SCALE THIS DRAWING

PROPRIETARY
This document is issued in strict confidence on condition that it is a third party, copy or in part, without written consent of Newport Scientific Inc.

NEUPORT SCIENTIFIC INC.
HYDRODYNAMICS

PREPARED BY	NAME	DATE	FINISH:
CHECKED			
DATE/ISSUE			
APPROVED			
MATERIAL			
CODE IDENT. NO.	SIZE	PART NO.	6380VD
59505	115/230VAC & 24VDC	ORDER NO.	6380WD
SCALE	WEIGHT	SHEET	1 of 1

TITLE TRANSMITTER WIRING