

HYGRODYNAMICS

DIGITAL DEW POINT MONITOR PC BOARD

MODEL 6392N & 6392N2

TABLE OF CONTENTS

INTRODUCTION	2
SPECIFICATIONS.....	2
INSTALLATION	3
PC Board Mounting	3
Sensor Installation.....	3
Manifold Assembly.....	4
WIRING.....	5
Power (TB1).....	5
Remote Alarm (TB1)	5
Sensor (TB1).....	5
Auxiliary Alarm Indication (TB2).....	6
Auxiliary Non-Alarm Indication (TB3).....	6
Recorder Output (TB3).....	6
Auxiliary Pump Power (TB5).....	6
Wiring Summary.....	7
OPERATION & MAINTENANCE	8
Alarm Set Point Adjustment	8
°F to °C Display Change.....	9
115V to 230V Change	9
Circuit Calibration	9
PRODUCT WARRANTY	10
ADDENDUM	
MOUNTING & WIRING DIAGRAM DWG # 6392NWD	

NEWPORT SCIENTIFIC, INC.
8246-E SANDY COURT
JESSUP, MARYLAND 20794-9632
PHONE: (301) 498-6700 FAX (301) 490-2313
E-MAIL: sales@newport-scientific.com
WEBSITE: WWW.NEWPORT-SCIENTIFIC.COM

INTRODUCTION

The 6392N is a Digital Dew Point Monitor PC Board with relay setpoint, digital display and linear transmitter. This product is ideal for OEM applications on desiccant dryers. A complete monitoring system includes the 6392N (or 6392N2), a 1205DM Hygrosensor, and a variety of supporting accessories.

SPECIFICATIONS

Dew Point Range	-40°F to +15°F (-40°C to -9°C)
Sensor Part #	1205DM
Alarm Set Point	-10°F ±2°F (Adjustable, see Calibration Section.)
Remote Alarm Output	Normally open and normally closed contacts, 5A @ 250VAC
Output Scaling	4-20mA and 0-5V representing -40 to +70°F

NOTE: Use one of the following equations when determining the corresponding dew point for milliamp or voltage outputs.

$$DP^{\circ}F = 6.875(\text{mA}) - 67.5$$

$$DP^{\circ}F = 22(\text{V}) - 40$$

Power Requirements	115 VAC ±10% (230 VAC model available) 50/60Hz 18 - 28VDC (24V model)
Power Consumption	150mA max on line powered models 200mA max on 24V models
Operating Temperature	32-122°F (0-50°C)
Board Dimensions	3.5"W x 5.75"H

INSTALLATION

The 6392N PC board is intended for permanent installations in industrial environments to monitor dew point of process air. When used with sensors and accessories from Newport Scientific, this board provides reliable, continuous measurement of air dew point. If the 6392N is used in a manner not specified in this manual, the operational safety of the unit may be impaired.

PC Board Mounting

The 6392N is designed to be mounted behind a panel with the built-in LED display showing through. Refer to 6392NWD addendum for suggestions on panel cutouts and mounting dimensions.

Standoffs used under the 6392N board should be at least ¼” long to maintain clearance between the board and the mounting panel.

WARNING: As part of the installation, the 6392N board must ultimately be housed in a suitable electrical enclosure. This enclosure must also serve as a suitable fire enclosure. The board itself is not designed to be exposed.

Sensor Installation

There are two basic sensing arrangements for measuring process air. Parts for either arrangement are available from Newport Scientific.

Remote Sensor- The sensor is housed in a manifold. This arrangement allows best control of measurement conditions. A filter can be used ahead of the manifold to ensure clean sample air, and a bleed valve or vacuum pump after the manifold provides constant air flow around the sensor.

The sensor manifold has two 1/8” NPT ports for connecting sample air tubing. Flow rate through the manifold should be between 1 and 5 SCFH.

Pipe Mount Sensor- The sensor is installed directly in a pipe fitting in the process air stream. This installation is simplest, but care should be taken to protect the sensor from oil or other contaminants.

Manifold Assembly

1. Plug sensor into the 2 pin insert. Press firmly, but note that the sensor does not need to seat fully into the 2 pin insert.
2. Place gasket over sensor and slide down until it seats against the lip of the 2 pin insert.
3. Slide sensor and 2 pin insert into manifold. Screw the hex nut onto manifold and hand tighten.

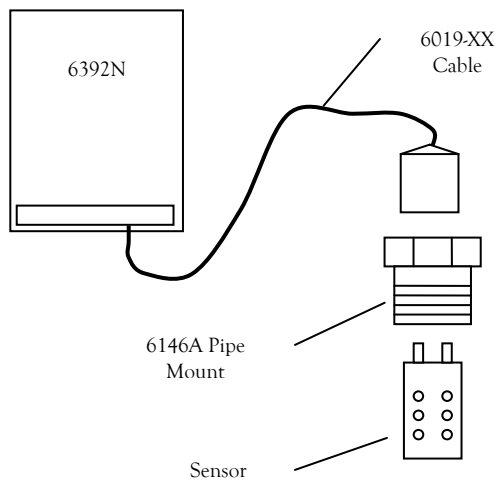

1" NPT Pipe Mount
Installation

OR

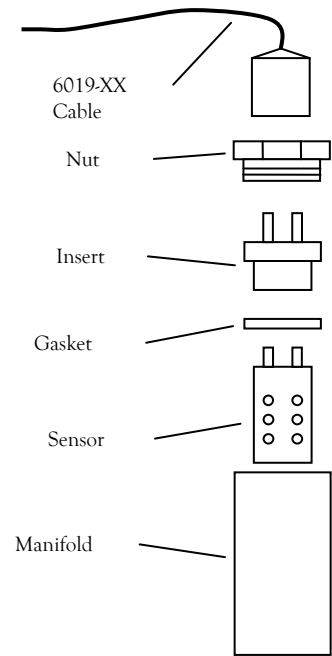

Remote Sensor
Installation

WIRING

Refer to 6392NWD addendum for terminal block locations.

Wiring to the 6392N board should be of the non-stranded, solid conductor type. If stranded conductor wire is used, the cut and stripped ends must be crimped or tinned to contain all loose strands.

WARNING: The 6392N board utilizes connections of hazardous line voltage and low voltage wiring together in close proximity. Care should be taken during installation to ensure that hazardous voltage wiring does not contact low voltage wiring or PC board components.

Wiring should be secured such that loosening of the terminals will not cause hazardous voltage wires to contact PC board components or sensor wires and vice-versa.

Power (TB1)

Wire used for power connection must be minimum 22AWG solid conductor wire rated 300VRMS. Protective ground wire must be at minimum the same size as wire used for power connection.

WARNING: An all-pole disconnect device should be installed in line with the 6392N power connections to allow safe servicing of the board. Any disconnect device used must not interrupt the connection to protective earth ground.

Connect line power to terminals HOT+ and NEUT-.

Connect circuit ground to the terminal marked .

It is recommended to fuse the supply to the board with a 0.5AMP fast acting fuse.

Remote Alarm (TB1)

The terminals labeled NC, COM, and NO are dry contacts used for alarm indication and control. The NC and COM are closed when there is no alarm. The NO and COM terminals close when an alarm occurs. An alarm occurs if the measured dew point exceeds the setpoint. If power to the board is removed, the NO and COM terminals close to indicate a fail-safe high dew point condition.

The relays are rated at 5A 250VAC. Use appropriate wire type for your application. It is recommended to limit the current through the relays to 5A with fusing if an overload is possible.

Sensor (TB1)

Sensor cable connects to terminals A and B. If the cable has a shield, the shield lead connects to the GND terminal next to A and B. The sensor leads have no polarity.

Auxiliary Alarm Indication (TB2)

A 12V signal at TB2 can be used to access alarm status. TB2 terminal 1 supplies 12V and terminal 2 is an open collector output that is pulled low when the setpoint is exceeded. Terminals 3 and 4 are available on 6392N2 models as a second alarm. The maximum load through each output is 20mA.

Auxiliary Non-Alarm Indication (TB3)

A 12V signal at TB3 can be used to access non-alarm status. TB3 terminal 4 supplies 12V and terminal 5 is an open collector output that is pulled low during a non-alarm condition. Terminals 6 and 7 are available on 6392N2 models as a second alarm. The maximum load through each output is 20mA.

Recorder Output (TB3)

The 6392N provides two outputs, 0-5VDC at terminal 1 and 4-20mA at terminal 3, which represent -40°F to +70°F. Terminal 2 is signal ground. Both outputs can be used simultaneously.

Auxiliary Pump Power (TB5)

115VAC is available on TB5. If the board is set for 230VAC, the voltage at TB5 is stepped down to 115VAC so only one pump type is needed for both applications. Maximum current available from TB5 is 50mA.

Wiring Summary

TB1 terminal #	Label	Function
1	HOT+	Line Hot (positive if 24V version board)
2	NEUT-	Line Neutral (negative if 24V version board)
3	⊕	Protective earth ground
4	NC1	Normally closed for relay #1
5	COM1	Common for relay #1
6	NO1	Normally open for relay #1
7	NC2	Normally closed for relay #2 (applies only to 6392N2)
8	COM2	Common for relay #2 (applies only to 6392N2)
9	NO2	Normally open for relay #2 (applies only to 6392N2)
10	A	Sensor lead
11	B	Sensor lead
12	GND	Power and signal ground
13	C	(not used)
14	D	(not used)
TB2 terminal #		Function
1		Aux alarm +12VDC source
2		Aux alarm open collector output relay #1
3		Aux alarm +12VDC source (applies only to 6392N2)
4		Aux alarm open collector output relay #2 (applies only to 6392N2)
TB3 terminal #		Function
1		Recorder output 0-5VDC
2		Power and signal ground
3		Recorder output 4-20mA
4		Aux non-alarm +12VDC source
5		Aux non-alarm open collector output relay #1
6		Aux non-alarm +12VDC source (applies only to 6392N2)
7		Aux non-alarm open collector output relay #2 (applies only to 6392N2)
TB5 terminal #		Function (Terminal TB5 is not available on 24V versions)
1		Pump power Hot (115VAC, 50mA max)
2		Pump power Neutral (115VAC, 50mA max)

OPERATION & MAINTENANCE

Field calibration of the Hygrosensor is impractical. To ensure continued accuracy, it is recommended that the sensor be replaced annually.

Alarm Set Point Adjustment

Locate the display function switch (S1). Note that only one position of this switch should be ON at a time.

1. **View and adjust relay #1 setpoint:** switch the OPER position of S1 to OFF and the SET1 position to ON. Adjust SET1 potentiometer to the desired setpoint.

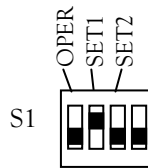

S1 Settings for Relay #1 setpoint view and adjustment

2. **View and adjust relay #2 setpoint:** switch the OPER position of S1 to OFF and the SET2 position to ON. Adjust SET2 potentiometer to the desired setpoint.

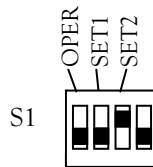

S1 Settings for Relay #2 setpoint view and adjustment

3. When finished adjusting the setpoints, return S1 to the default operating mode by switching OPER position ON and all others OFF.

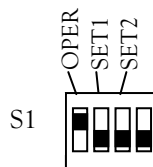

S1 Settings for normal operation

A small red LED near the potentiometer SET1 or SET2 indicates when an alarm is occurring.

°F to °C Display Change

To change the digital display to °C, move jumpers J6 and J7 to the C position.

115V to 230V Change

WARNING: Disconnect power to the board before changing the operating voltage jumpers.

Remove jumper J1 and J3 and install jumper J2.

Circuit Calibration

NOTE: 6392N is supplied fully factory calibrated. This procedure is only necessary if circuit is thought to be malfunctioning.

1. Apply power and measure tab of U201 (voltage regulator below TB3). Adjust P4 for 5.00V.
2. With no sensor connected to terminals A and B, measure PIN 6 of U7. Check for $0.0V \pm 0.05V$. Check terminal 3 of TB3 for $4.0mA \pm 0.1mA$.
3. Place a jumper across sensor terminals A and B and adjust P1 for 5.00V at PIN 6 of U7. Check terminal 3 of TB3 for $12.0mA \pm 0.1mA$.
4. If these parameters cannot be met, contact Newport Scientific about factory service on PC board.

PRODUCT WARRANTY

HYGRODYNAMICS

LIMITED WARRANTY

NEWPORT SCIENTIFIC, INC. warrants that all equipment manufactured by NSI shall be free from defects in material and workmanship which might impair its usefulness. SELLER DOES NOT WARRANT THAT THE EQUIPMENT IS FIT FOR ANY PARTICULAR USE. THERE ARE NO WARRANTIES WHICH EXTEND BEYOND THE DESCRIPTION ON THE FACE HEREOF; the obligation under this warranty is limited to repairing or replacing, at Seller's factory, any defective parts which, when returned by the buyer, **TRANSPORTATION PREPAID**, examination discloses to have been factory defective. The time limit of this warranty is ONE YEAR from date of shipment of new equipment, SIX MONTHS from date of shipment of Hygrodynamics Wide-Range Sensors and THREE MONTHS from date of shipment of Hygrodynamics Narrow-Range Sensors and repaired equipment. THIS WARRANTY IS EXPRESSLY IN LIEU OF OTHER WARRANTIES. Seller shall not be held liable for any special, indirect, consequential damages arising out of this warranty or any breach thereof, of any defect in or failure or malfunction of the equipment and materials are further subject to tolerances and variations consistent with usages of trade. This warranty shall run in favor only of the purchaser from Seller and may not be passed on or represented on behalf of Seller to any subsequent purchaser.

WARRANTIES: OTHER PRODUCTS

NEWPORT SCIENTIFIC, INC. makes no express or implied warranty as to items, which are the products of other manufacturers. Seller shall use its best efforts to obtain from the manufacturer, in accordance with its customary practice, the repair or replacement of such products may prove defective in workmanship or material. The foregoing states the entire liability in respect to such products, except as an authorized executive of the corporation may otherwise agree in writing.

In the case of special equipment or modifications to standard equipment manufactured at the request of the buyer, under buyer-approved specifications, buyer will indemnify Seller against the risk damages due to patent infringement.

REV	DATE	CHANGES
A	2001	INITIAL RELEASE
B	2/16/2007	J6 AND J7 RECONFIGURE

UNITS PRE-2007 J6 AND J7 ORIENTED AS SHOWN:

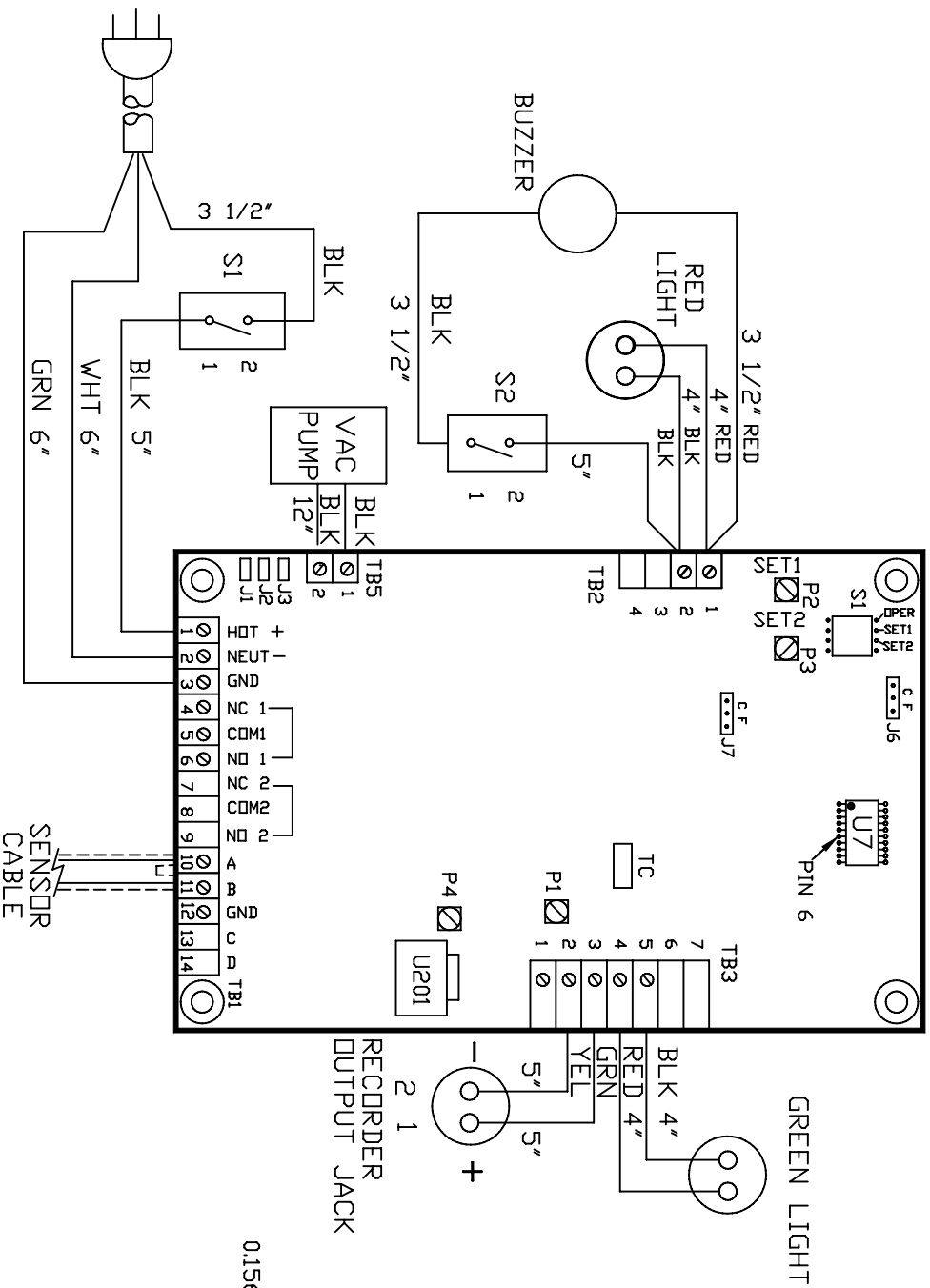

NOTES:

1. WIRE LENGTHS TYP FOR 8072

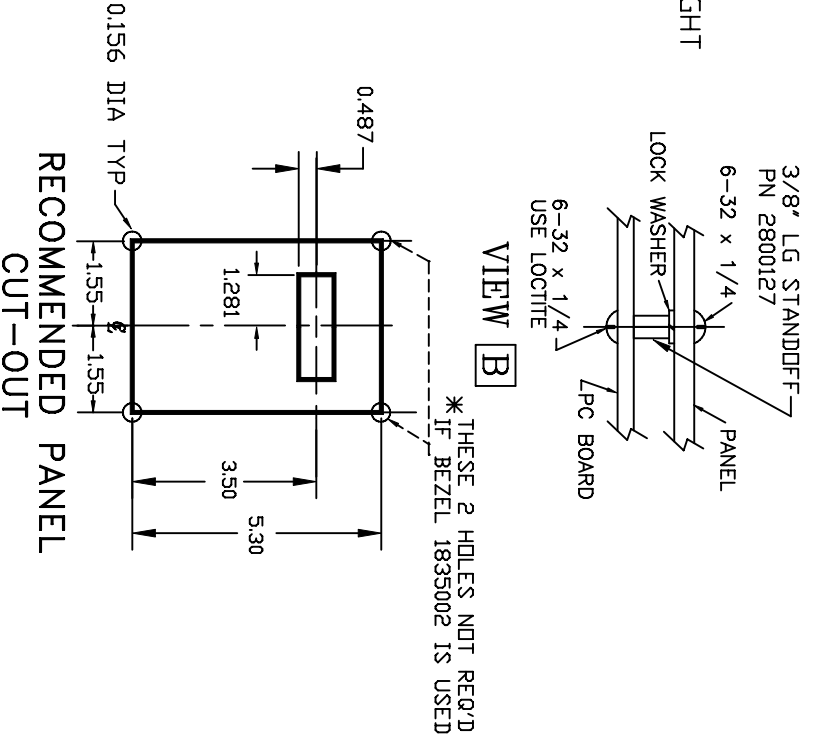
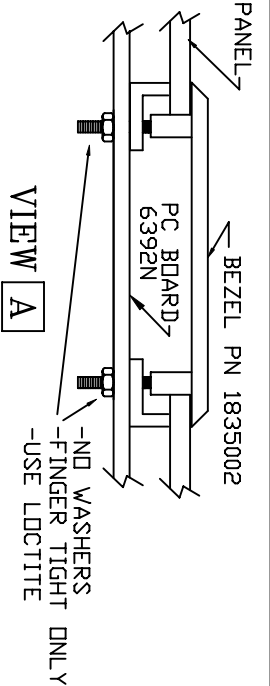

UNLESS OTHERWISE SPECIFIED DIMENSIONS ARE IN INCHES TOLERANCES: FRACTIONS ± DECIMALS ± ANGLES ±		<p>PROPRIETARY</p> <p>This document is issued in strict confidence on condition that it is not copied, reprinted, or disclosed to a third party, wholly or in part, without written consent of Newport Scientific Inc.</p>
DO NOT SCALE THIS DRAWING		
BY	NAME	DATE
PREPARED		
CHECKED		
ENGR./ISSN		
APPROVED		
MOUNTING & WIRING		
CODE IDENT. NO.	FOR 6392N & 6392N2 D/P BOARD	
SIZE	59505	PART NO. 6392NWD DRAWING NO. 6392NWD
SCALE	WEIGHT	SHEET OF

