

HYGRODYNAMICS

DEW POINT MONITOR

MODELS

8092

8092-230V

8092W2

8092REMOTE

TABLE OF CONTENTS

INTRODUCTION	2
SPECIFICATIONS.....	2
INSTALLATION	3
WIRING.....	3
OPERATION.....	4
CALIBRATION & MAINTENANCE.....	5
Sensor Replacement Procedure	5
Alarm Set Point Adjustment	6
°F to °C Display Change.....	7
Replacement Parts.....	7
PRODUCT WARRANTY	8
ADDENDUM	
WIRING DIAGRAM DWG # 6392WWD	

Newport Scientific, Inc
8246-E Sandy Court
Jessup, Maryland 20794-9632
www.newport-scientific.com

e-mail
sales@newport-scientific.com

Phone
301.498.6700

FAX
301.490.2313

INTRODUCTION

The 8092 Dew Point Monitor operates by bleeding off compressed air that has passed through an internal sensor manifold. The REMOTE version places the sensor directly in the process air line. The sensor is comprised of a 3 element humidity device and a temperature transducer. With humidity and temperature signals the circuitry can provide temperature compensated dew point measurement.

Because the sensor is exposed to line pressure, the monitor reads the true pressure dew point of the air in the system it is monitoring.

SPECIFICATIONS

Dew Point Range:	+10°F to +70°F (at +73°F sample air temp) 0°F to +50°F (at +50°F sample air temp) +35°F to +90°F (at 100°F sample air temp)
Process Air Temp.:	+50°F to +100°F (process air temp is approximately equal to ambient air temp except on REMOTE version)
Accuracy:	±3°F
Pressure Range:	5-150psig 0-300psig on REMOTE version
Alarm Indication:	Red Light and Audible Alarm with Silencer Switch
Alarm Output:	Normally Open and Normally Closed Dry Contacts Rated @ 5AMP, 115VAC. (W2 model has two alarm points)
Recorder Output:	4-20mA or 0-5V scaled as -40°F to 70°F $MA = \frac{DP + 67.5}{6.875} \quad \text{or} \quad V = \frac{DP + 40}{22}$ -40 = 4mA or 0V 70 = 20mA or 5V
Enclosure:	NEMA-12 Electrical Box, CSA Approved. Wall Mountable or Portable With Removable Front Cover.
Dimensions:	10-1/2" x 8-1/2" x 6"
Net Weight:	7.4 lbs.
Power Requirements:	115VAC ±10% 50/60Hz 0.1 AMPS (230V available)

INSTALLATION

Choosing a Process Air Sampling Location

The best sampling location is usually the main distribution line of the air system. Follow these guidelines when selecting a sampling location:

1. Sample air should be free of oil, particulates, and condensation.
2. Install an inline filter between sampling location and dew point monitor.
3. Be aware of ambient and sample air temperature limitations listed in SPECIFICATIONS section.

When a suitable location is found, install a 1/8" NPT female fitting in your air line for connection of the Dew Point Monitor. The Monitor is supplied with a 1/8" NPT male to compression adapter with tubing provided.

The 8092REMOTE comes with the sensor housed in a 1" male NPT pipe fitting. A 9 foot cable connects the sensor fitting to the 8092REMOTE enclosure. Install a tee fitting into the process air line to accept the 1" NPT sensor fitting.

Mounting the Enclosure

Remove the screws that hold the brackets on the backside of the unit. Re-install brackets so the flanges extend beyond the top and bottom of the enclosure. Mount the enclosure to a chosen location with bolts (not supplied). Connect the supplied plastic tubing to the sampling location and to the Dew Point Monitor air inlet.

WIRING

Refer to wiring diagram 6392WWD at the end of this manual for terminal block locations. Route wires through the liquid tight fitting on the side of the Dew Point Monitor to access the terminal blocks inside the unit.

Remote Alarm Connection (TB1)

Terminal	Function
4	Normally Closed #1
5	Common #1
6	Normally Open #1
7	Normally Closed #2 (W2 units only)
8	Common #2 (W2 units only)
9	Normally Open #2 (W2 units only)

The terminals labeled NC, COM, and NO are dry contacts used for alarm indication and control. The NC and COM are closed when there is no alarm. The NO and COM terminals close when an alarm occurs. An alarm occurs if the measured dew point exceeds the setpoint. If power to the board is removed, the NO and COM terminals close to indicate a fail-safe high dew point condition.

The relays are rated at 5A 250VAC. Use appropriate wire type for your application. It is recommended to limit the current through the relays to 5A with fusing if an overload is possible.

Note that on W2 models, the front panel lights and audible alarm are associated with alarm #1 of the unit.

Recorder Output Connection (TB3)

Terminal	Function
1	0-5V output
2	Ground
3	4-20mA output

Both 0-5V and 4-20mA outputs are available. Scaling for output is:

$-40^{\circ}\text{F}=0\text{V or }4\text{mA}; +70^{\circ}\text{F}=5\text{V or }20\text{mA}.$

OPERATION

NOTE: The 8092REMOTE has no flow control or pressure gauge since the sensor is located directly in the process air line.

On the Dew Point Monitor front panel, close the valve on the flow meter by turning clockwise. Start your compressed air system and observe the pressure on the Dew Point Monitor’s gauge. Adjust the Dew Point Monitor flow accordingly: Line pressures around 100 psig should have a flow of about 40 SCFH. Line pressures around 50 psig should have a flow of about 25 SCFH. Carefully open the flowmeter’s valve until you get adequate flow. This adjustment is not critical to the accuracy of the dew point reading, but inadequate flow will slow the response time of the monitor to changes in sample dew point.

Avoid excessive flow through the Dew Point Monitor which can cause a pressure drop across the sample tubing. A drop in pressure will cause an error in the true pressure dew point reading of the unit.

NOTE: The built in audible alarm can be silenced with the ALARM switch on the front panel. This switch does not affect the status of the remote alarm output.

On W2 models, the front panel lights and audible alarm are associated with alarm #1.

CALIBRATION & MAINTENANCE

The Dew Point Monitor normally does not require calibration, and in most applications the sensor will provide years of service. However, the easiest and most reliable way to ensure consistent accuracy is to replace the sensor annually.

Sensor Replacement Procedure

Replacement of the sensor is recommended on a yearly basis.

Remove power to the Dew Point Monitor before servicing.

1. Open the front cover and locate black sensor manifold.
2. Loosen hex nut on manifold and slide nut along wires away from manifold.
3. Lift 4 pin insert out of manifold to reveal sensor assembly.
4. Use a blunt object to pry sensor assembly out of 4 pin insert.
5. Observe the pin pattern on the new sensor assembly and match to the 4 pin insert. Use moderate finger pressure to press in the new sensor assembly. The sensor does not need to seat fully into the 4 pin insert.
6. Replace sensor assembly and 4 pin insert into manifold and hand tighten the hex nut.

On 8092REMOTE models, the sensor is housed in the 1" NPT process air fitting. To access the sensor, remove the packing nut and slide the 4 pin insert out of the fitting along with the sensor. Follow the steps above to remove and replace the sensor element. When replacing the 4 pin insert and packing nut, torque the nut hand tight or just beyond.

Alarm Set Point Adjustment

The dew point at which an alarm occurs can be changed. The unit must be opened for this procedure so **remove power before proceeding**.

Open the front cover to see the PC board inside the unit.

WARNING

THE FOLLOWING PROCEDURE IS PERFORMED WITH POWER APPLIED. TO PREVENT SHOCK, DO NOT TOUCH ANY TERMINALS INSIDE THE DEW POINT MONITOR.

Apply power to the unit and turn it on with care, making sure not to touch any electrical components inside. Locate the display function switch (S1) near the upper left corner of the PC board. Note that only one position of this switch should be ON at a time.

Setpoint #1 Adjust

Switch the OPER position of S1 to OFF and the SET1 position to ON. The LED display shows the current setpoint. Adjust SET1 potentiometer to the desired alarm setpoint.

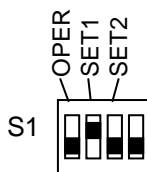

S1 setting for alarm setpoint #1 view and adjustment

When finished adjusting the alarm setpoint, return S1 to the default operating mode by switching OPER position ON and all others OFF.

Setpoint #2 Adjust (only on W2 models)

Switch the OPER position of S1 to OFF and the SET2 position to ON. The LED display shows the current setpoint. Adjust SET2 potentiometer to the desired setpoint.

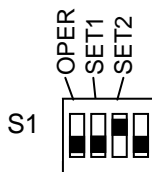

S1 settings for alarm setpoint #2 view and adjustment

When finished adjusting the alarm setpoint, return S1 to the default operating mode by switching OPER position ON and all others OFF.

Normal Operation

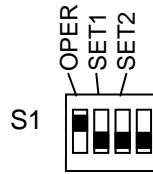

S1 setting for normal operation

°F to °C Display Change

The unit must be opened for this procedure so **remove power before proceeding.**

Open the front cover to see the PC board inside the unit.

To change the digital display to °C, move jumpers J6 and J7 to the C position.

Replacement Parts

1826-2	Wide Range Sensor
0900104	4 Pin Insert
1000613	Sensor Gasket
6148C	1" NPT sensor mount (used on 8092REMOTE)

PRODUCT WARRANTY

HYGRODYNAMICS

LIMITED WARRANTY

NEWPORT SCIENTIFIC, INC. warrants that all equipment manufactured by NSI shall be free from defects in material and workmanship which might impair its usefulness. SELLER DOES NOT WARRANT THAT THE EQUIPMENT IS FIT FOR ANY PARTICULAR USE. THERE ARE NO WARRANTIES WHICH EXTEND BEYOND THE DESCRIPTION ON THE FACE HEREOF; the obligation under this warranty is limited to repairing or replacing, at Seller's factory, any defective parts which, when returned by the buyer, **TRANSPORTATION PREPAID**, examination discloses to have been factory defective. The time limit of this warranty is ONE YEAR from date of shipment of new equipment, SIX MONTHS from date of shipment of Hygrodynamics Wide-Range Sensors and THREE MONTHS from date of shipment of Hygrodynamics Narrow-Range Sensors and repaired equipment. THIS WARRANTY IS EXPRESSLY IN LIEU OF OTHER WARRANTIES. Seller shall not be held liable for any special, indirect, consequential damages arising out of this warranty or any breach thereof, of any defect in or failure or malfunction of the equipment and materials are further subject to tolerances and variations consistent with usages of trade. This warranty shall run in favor only of the purchaser from Seller and may not be passed on or represented on behalf of Seller to any subsequent purchaser.

WARRANTIES: OTHER PRODUCTS

NEWPORT SCIENTIFIC, INC. makes no express or implied warranty as to items, which are the products of other manufacturers. Seller shall use its best efforts to obtain from the manufacturer, in accordance with its customary practice, the repair or replacement of such products may prove defective in workmanship or material. The foregoing states the entire liability in respect to such products, except as an authorized executive of the corporation may otherwise agree in writing.

In the case of special equipment or modifications to standard equipment manufactured at the request of the buyer, under buyer-approved specifications, buyer will indemnify Seller against the risk damages due to patent infringement.

REV	DATE	CHANGES
A	2001	INITIAL RELEASE
B	2/16/2007	J6 AND J7 RECONFIGURE

UNITS PRE-2007 J6 AND J7 ORIENTED AS SHOWN:

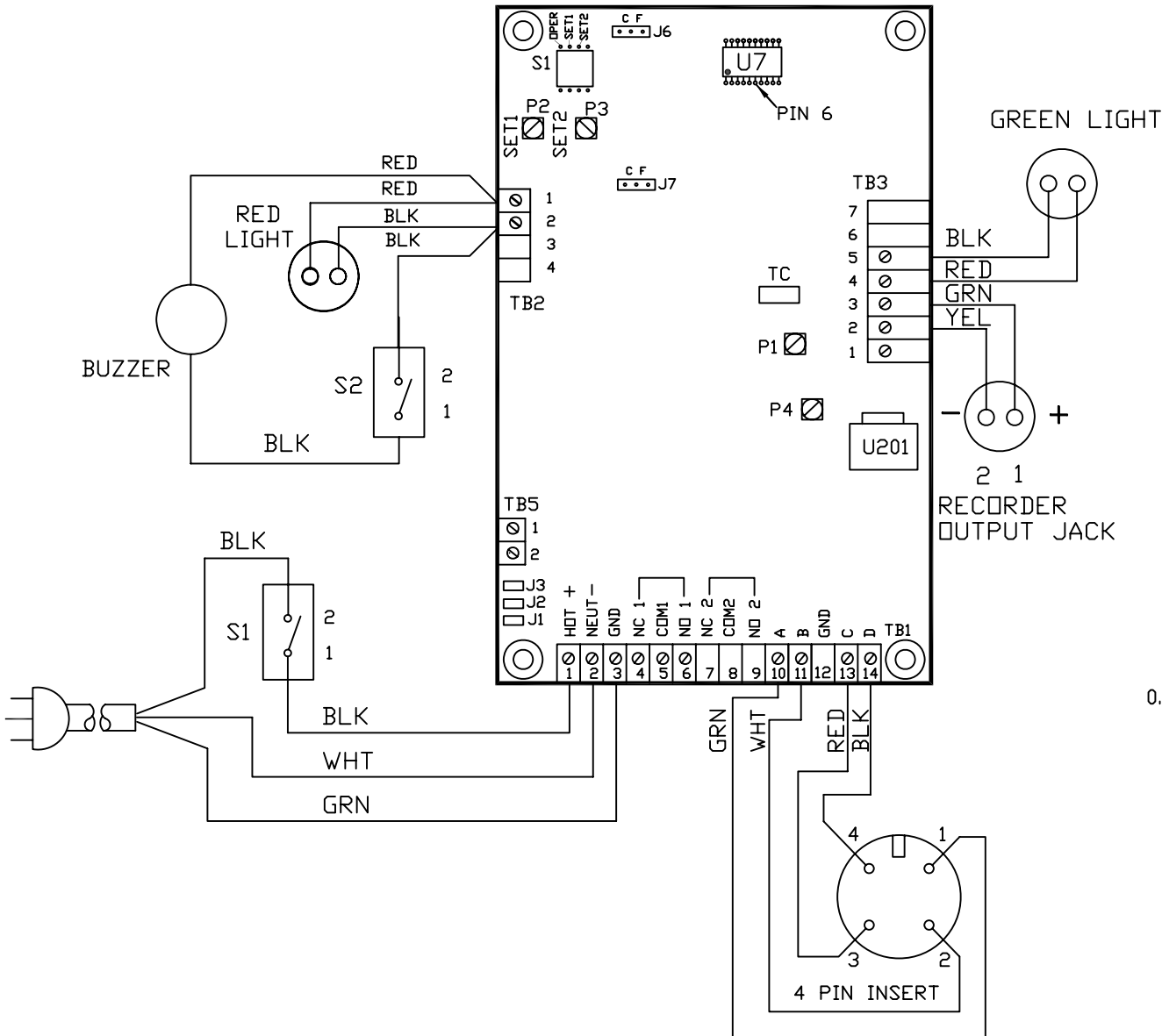

NOTE: RED & GREEN LIGHTS ARE OPTIONAL.

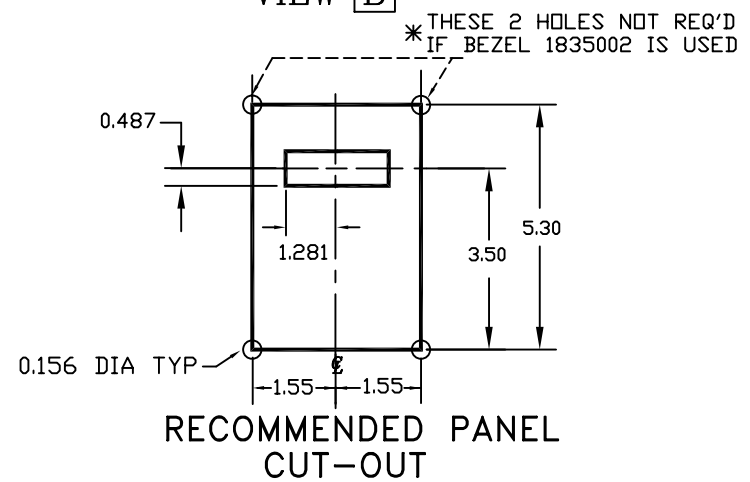
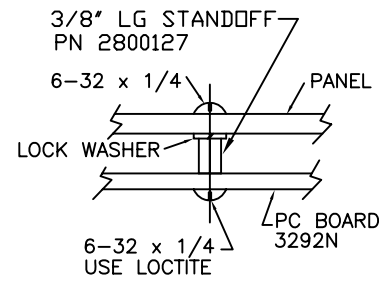
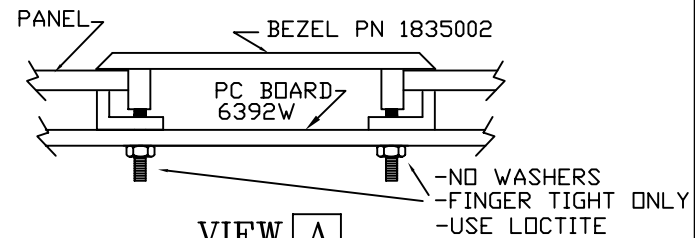

UNLESS OTHERWISE SPECIFIED DIMENSIONS ARE IN INCHES TOLERANCES:			PROPRIETARY This document is issued in strict confidence on condition that it is not copied, reprinted, or disclosed to a third party, wholly or in part, without written consent of Newport Scientific Inc.
FRACTIONS ± DECIMALS ± ANGLES ±			
REMOVE ALL BURRS AND SHARP EDGES DO NOT SCALE THIS DRAWING			HYGRODYNAMICS ® NEWPORT SCIENTIFIC INC.
BY	NAME	DATE	
PREPARED			MOUNTING & WIRING FOR 6392W & 6392W2 D/P BOARD
CHECKED			
ENGR/DSGN			
APPROVED			
MATERIAL	CODE IDENT. NO. 59505	SIZE	PART NO. 6392WWD DRAWING NO. 6392WWD
	SCALE	WEIGHT	SHEET OF